

SARGENT®

ASSA ABLOY

281 Series Powerglide®

Cast Iron Door Closer

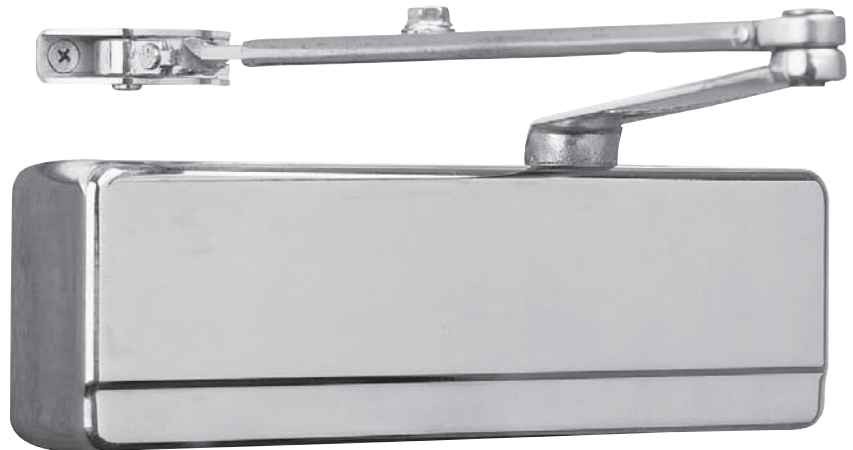

Table of Contents

281 Series Powerglide®

General Information.....	1
Features and Benefits.....	2
Suggested Architect's Specifications.....	3
Standard Applications.....	4
Arms for Standard Applications.....	5
Top Jamb Applications.....	6
Arms for Top Jamb Applications.....	7
Parallel Arm Applications.....	8
Heavy Duty Parallel Arms.....	9
Regular Duty Parallel Arms.....	10
Accessories for Parallel Applications.....	11
Track Type Applications.....	12
Standard & Parallel Arm Security Solutions.....	13
Track Type Security Solutions.....	14
Overhead Stop/Holder Compatibility.....	15
How to Order & Options.....	16
Finishes.....	17

The 281 Powerglide® line of surface door closers has been engineered to meet the demands of architects and building owners. The 281 Series is a complete line of closers for interior and exterior doors with quality and flexibility to meet virtually every application.

Primary Closer Arm Identification Letters

O	Standard Arm
H	Hold Open Arm
F	Fusible Link Hold Open Arm
Z	Deep Reveal Arm 2-1/8" to 5"
ZA	Extra Deep Reveal Arm 5-1/8" to 8"
P	Parallel Arm or Push Side
S	Arm with Positive Stop
C	Arm with Positive Cushioned Stop "C" is always accompanied by an "S" (Stop)

Note: Often more than one letter is used to describe one type of arm.

Underwriters' Laboratories Listing

All SARGENT Powerglide® Door Closers are listed by the Underwriters' Laboratories, Inc. as follows:

"For Self-Closing Doors Without Hold-Open Feature"

"For Automatic Doors With Hold-Open Arm Embodying Fusible Link Release"

Any retrofit or other field modification to a fire rated opening can potentially impact the fire rating of the opening, and Sargent Manufacturing Company makes no representations or warranties concerning what such impact may be in any specific situation. When retrofitting any portion of an existing fire rated opening, or specifying and installing a new fire-rated opening, please consult with a code specialist or local code official (Authority Having Jurisdiction) to ensure compliance with all applicable codes and ratings.



SARGENT®

ASSA ABLOY



MicroShield®

As part of their promise to provide innovative solutions to their customers, certain ASSA ABLOY Group brands offer the MicroShield® technology, a silver-based antimicrobial coating designed to inhibit the growth of bacteria. MicroShield® is a registered trademark of Yale Security Inc., an ASSA ABLOY Group company.

MicroShield® Coating

- Revolutionary finish coating available on all SARGENT product lines, utilizes a silver-based antimicrobial compound from Agion Technologies
- As an integral part of the finish coating, MicroShield® lasts for the life of the hardware
- MicroShield® coating permanently suppresses the growth of bacteria, algae, fungus, mold and mildew. It is effective against a broad spectrum of bacteria.
- Non-toxic and completely safe. The Agion antimicrobial compound is EPA and NSF approved and FDA listed for use in medical and food preparation equipment.
- Applications: Anywhere there is need for a clean environment (hospitals, laboratories, schools, medical centers, daycare, food processing etc.)



Agion has achieved:



Agion's silver antimicrobial has been certified for its material content, recyclability, and manufacturing characteristics. Cradle To Cradle Certified^{CM} products meet established standards for human health, environmental health and recyclability.

Cradle To Cradle Certified^{CM} is a certification mark of MBDC.

On The Cover

- SARGENT 281 Door Closer with US26 plated O arm and metal cover

General Information

281 Series Powerglide®

All Weather Fluid

All 281 Series closers are equipped with fluid that allows the units to operate effectively in extreme temperatures without readjustment.

Finishes

Powder coated and plated finishes are available. See How to Order page 16.

BHMA CERTIFIED ANSI/BHMA Specifications

- The 281 Series door closers are certified to the ANSI A156.4 Grade 1 requirements
- Complies with UL-10C and UBC 7-2C (1997) Positive Pressure Fire Test

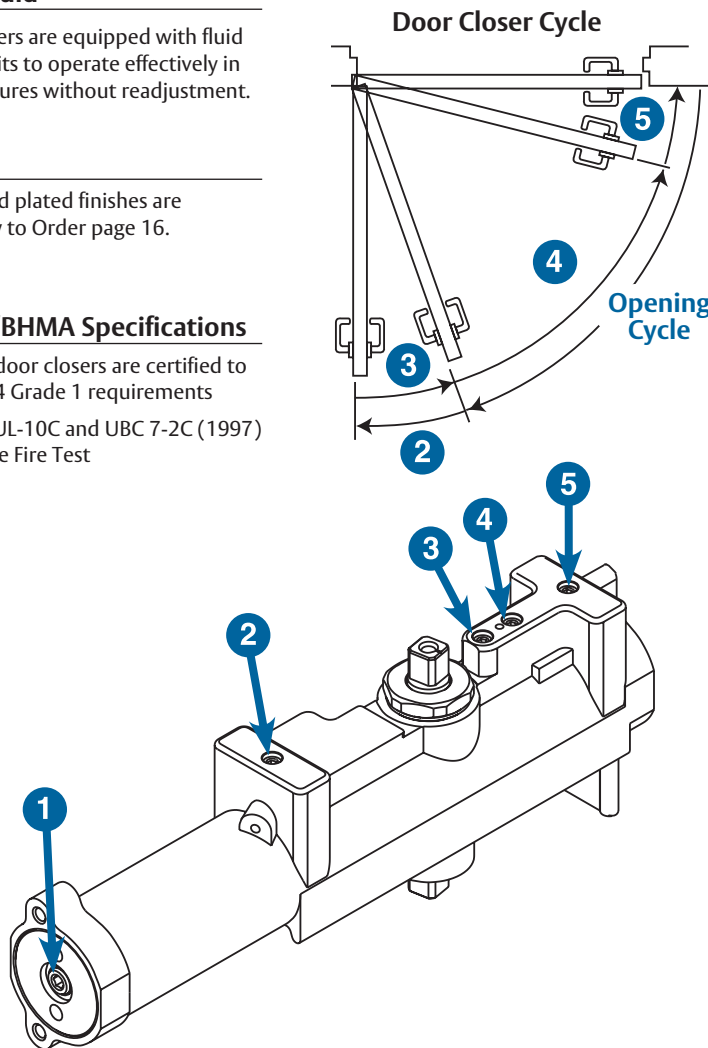

1 Closer Spring Adjustment (not shown)

- Effects the entire cycle of the door closer movement
- Used to size closer for application requirements
- Determines the amount of force with which the door closes and the amount of force required to open the door
- Adjustable to compensate for door size and draft conditions

2 Backcheck Valve

- At approximately 70° of the open cycle, the backcheck valve begins to slow the door's motion
- Prevents the door from slamming into the door's stop
- Valve is used to control the intensity of the backcheck
- Note: A Positive stop is required, Backcheck cannot be used as a stop

3 Delayed Action Valve (Optional)

- Holds the door in the open position momentarily
- 20 second minimum hold open delay
- The feature is available for all applications and arms
- Beneficial for ADA applications and when moving carts or objects thru door opening

4 Closing Speed Valve

- Controls how fast the door closes to approximately 8" from the closed position

5 Latching Speed Valve

- Controls the speed of the door during the final 8" of door swing
- The force the door closes with is controlled by the closer spring
- Note: This adjustment is critical for door latching

How to Select the Proper Closer

Things to Consider

1. Size and Weight of Door

The 281 Door Closer is non-sized so that closing force can be adjusted in the field to accommodate various door sizes and weights.

2. Interior Application

The standard application is the most efficient in terms of power and control.

3. Exterior Application

The top jamb, corner bracket or parallel arm application should be used. Exterior doors require greater closing forces because of draft conditions. Always place the closers out of the weather.

4. Degree of Opening

Proper arm and position on the door is most important to permit the door to open far enough to allow adequate traffic flow.

5. Function

Closers are available with hold-open, positive stop or fusible link hold-open arms.

6. Special Condition

Consult factory when special hinges, overhead holders or other specialized hardware is used.

ANSI Standards

ARM	TYPE	ARM	TYPE
O	CO2011	PF9	CO2101
P9	CO2021	P10	CO2021
H	CO2051	PS/CPS	CO2021
PH9	CO2061	CPSH/PSH	CO2061
F	CO2091		

All are certified ANSI types including options PT4 A, B, D, E, F, G, H

Suggested Architect's Specification

281 Series Powerglide®

SARGENT®

ASSA ABLOY

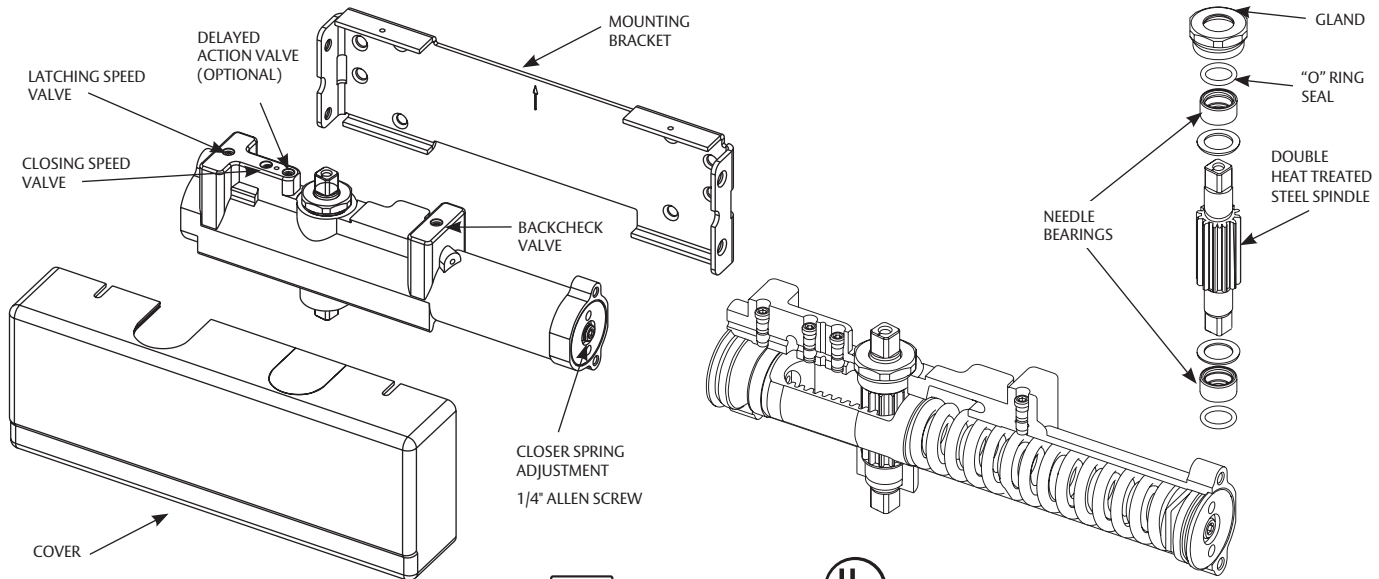

The 281 Series complies with ADA for reduced open forces of 5 lbs. for interior and 8 lbs. for exterior doors.



Features

- Exceeds 10 million cycles
- Certified ANSI/BHMA A156.4 Grade 1
- Conforms to UL10C and UBC for positive pressure fire test
- UL Listed and cUL Listed to Canadian Safety Standards listed for use on fire doors
- 25 year limited warranty
- User friendly versatile mounting applications permit standard, top jamb, parallel and track installations
- Self sticking templates supplied for most applications
- Adjustable spring power allows 281 closers a size range of 1 through 6. They are adjusted to size 3 before leaving the factory
- One door closer body for all applications
- 281 are non-handed
- Meets ADA requirements in all applications, except Push Side Track application (except track)
- High impact non-corrosive plastic covers with two machine screws standard, ABS covers, metal covers and lead lined are optional
- All weather fluid allows closer to operate effectively in extreme temperatures without readjustment
- 1-1/2" diameter piston for superior door control
- Standard pressure relief valves for both opening and closing cycles protect the door & frame from damage caused by abuse

- Heavy duty mounting bracket for easy installation of full size iron closer
- Retrofits existing SARGENT 250 and 1250 Series Closer installations
- The Advanced Backcheck (ABC) option begins to slow the door down at approximately 15° sooner than standard backcheck in the open cycle. The (ABC) option is used when the door needs to slow down earlier than the standard back check of 70°

Heavy Duty Construction

- Heat treated full rack and pinion for high strength & wear resistance
- Heavy duty one piece cast iron body provides superior strength and wear resistance
- 1/2" arm engagement over a 7/16 square spindle ensures a wear-resistant tight joint

Fasteners

- Machine Screws and self tapping screws provided for closer and arm
- In addition, wood screws supplied when installed on wood doors without through bolts

Full Complement of Arm Types

- Standard and parallel arms
- Push and pull track arms
- Security track
- Security parallel arm
- Heavy duty forged steel arms are finely finished and interchangeable between SARGENT 281 and 1431, 250, 1250 and 351 Series

Valves

- Separate brass low sensitivity control valves offer ability to separately regulate door speed, latching, backcheck and optional delayed action
- All valves are captured to prevent accidental removal, adjustable with an 1/8" allen wrench
- Adjustable backcheck protects the door and hardware from damage during the opening cycle. Not to be used in lieu of a door stop
- Adjustable delayed action (optional) permits easy access for physically impaired individuals

Innovation

- SARGENT's revolutionary MicroShield® available. This antimicrobial silver-based finish coating permanently suppresses the growth of bacteria, algae, fungus, mold and mildew. EPA and NSF approved and FDA listed.

Copyright © 2005-2007, 2009-2012, Sargent Manufacturing Company, an ASSA ABLOY Group company. All rights reserved. Reproduction in whole or in part without the express written permission of Sargent Manufacturing Company is prohibited.

901194 11/16/12

Features and Benefits

281 Series Powerglide®

SARGENT®

ASSA ABLOY

Architectural Specifications

1. All closers for both interior and exterior doors shall be the product of one manufacturer and be matched in style.
2. Surface closers shall be adjustable to provide sizes 1 through 6 and comply with ADA.
3. Full rack and pinion construction.
4. Closing speed, latching speed and backcheck shall be controlled by key operated valves.
5. Delayed action feature shall be available and controlled by a separate valve. Delayed action shall be available in addition to, not in lieu of, backcheck.
6. The one piece closer body shall be of close grained porous free cast iron with a minimum wall thickness of 5/32" (4mm).
7. An increase of 15% in closing power shall be provided by means of adjustment of the arm leverage at the foot connection. (Standard Arm)
8. All arms shall be finely finished with heavy duty forged steel main arm.
9. Two mounting positions of the closer shall meet all requirements. Standard mountings shall provide 120° door opening and alternate mounting 180° door opening.
10. All closers shall be suitable for standard, corner bracket, top jamb, parallel arm and track type applications when provided with proper brackets and arms.
11. Closer covers shall be of high impact plastic material of flame retardant grade, secured by machine screws.
12. Projection of closer body from door shall not exceed 2-3/16" (56mm).
13. Closers shall be non-handed to meet a variety of door conditions and design requirements.
14. The spindle shaft shall be sealed hydraulically with an "O" ring.
15. Specify desired options such as: Metal Cover, Security Package, (SRI) Special Rust Inhibitor Process, (ABC) Advanced Back Check, (TB) Through-bolting, (DA) Delayed Action and Architectural Plated Finishes.
16. Closers should have two pressure relief valves (opening and closing cycles).
17. All closers to have a 25 year limited warranty.
18. Closers should comply with UL-10C and UBC 7-2 (1997) Positive Pressure Fire Test.

The 281 door closer is designed to meet the opening force requirements established by the Americans with Disabilities Act defining 5 lbs. of opening force for interior and 8 lbs. for exterior doors. A special spring design affording easier access and allowing exterior door control is used. Where excessive draft and pressure conditions exist or when extra heavy doors are used, the spring should be adjusted for a stronger setting. Meeting ADA requirements can be achieved at all applications shown above with simple spring adjustment. Various field conditions (drafts) exist that make the use of ADA adjustments ineffective.

Standard Applications

281 Series Powerglide®

SARGENT®

ASSA ABLOY

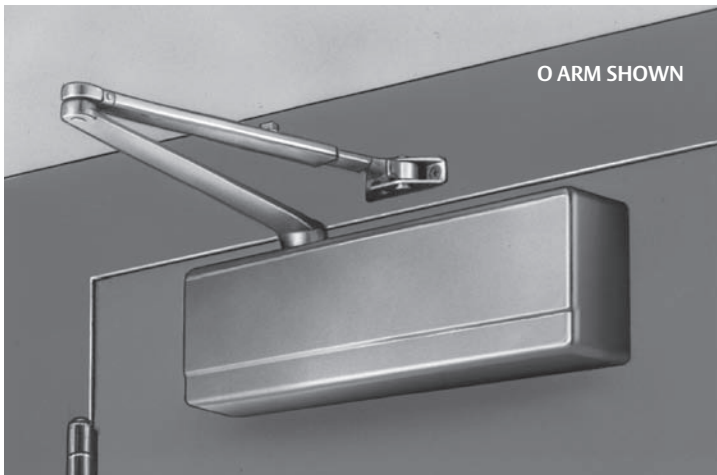

281-O Standard Application

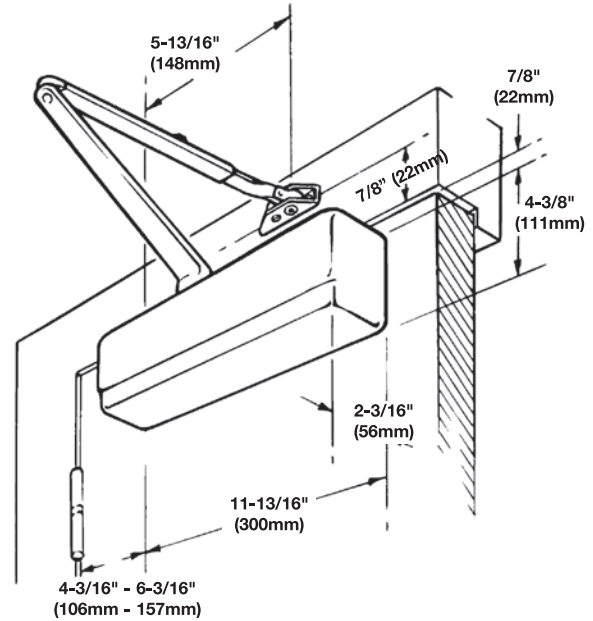

The standard application of the 281 door closer is the most common providing high degree of door control and range of power adjustment. The closer is mounted on the pull side of the door with the arm mounted on the face of the frame. When the door opens, the arm passes over the top of the door.

281 Standard Application for:

- Interior Doors Opening In or Out
- Exterior Doors Opening In
- 1-1/2" minimum frame face with a 2-5/8" door top rail or greater

Note: Base on the application & arm; verify door & frame requirements using the appropriate template

1 1/2" MIN. SPACE
REQUIRED FOR ARM
CLEARANCE WHEN TOP
RAIL OF DOOR IS 2 5/8"
OR GREATER.

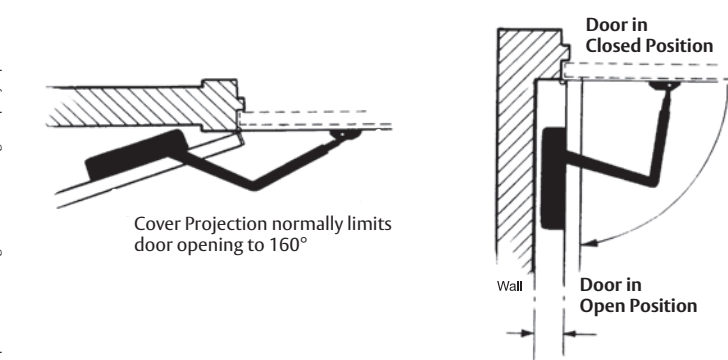
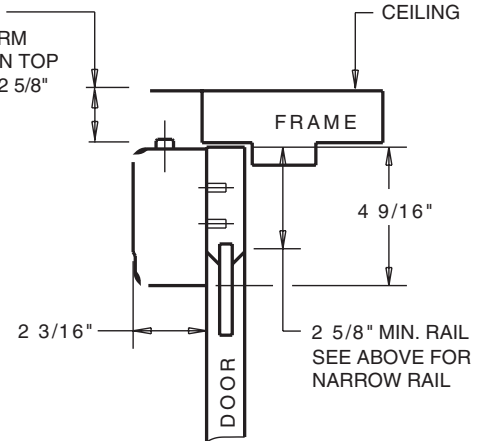

Regular Duty Standard Arms

For use in moderate duty institutional applications

- Two piece sliding arm provides flexibility and ease of installation
- Double jointed arms allow flexibility in vertical mounting position
- Friction and fusible hold open arms available
- Mortised feet available for special frame applications

Heavy Duty Standard Arms

For use in abusive or high use installations

- Solid forged steel arms provide strength
- Friction hold open arm available
- Oil bronze bearings provide a high degree of wear resistance
- 2 piece rigid arms for ease of installation

Copyright © 2005-2007, 2009-2012, Sargent Manufacturing Company, an ASSA ABLOY Group company. All rights reserved. Reproduction in whole or in part without the express written permission of Sargent Manufacturing Company is prohibited.

901194 11/16/12

Arms for Standard Applications

281 Series Powerglide®

Regular Duty Standard Arms

O - Standard Arm

- Forged Steel Arm 11-1/4" (286mm) long
- Non-handed
- Permits 120° door opening with standard mounting
- Permits 180° door opening with alternate mounting or corner bracket



Order as 25-O x finish for arm only
Includes: 63-2607 - Main arm and link assembly
63-2216 - Foot assembly
63-3481 - Screw pack

H - Hold Open Arm

- Forged Steel Arm 11-1/4" (286mm) long
- Non-handed
- Hand is changed by inverting the foot assembly
- Friction type holder easily adjustable
- Permits 180° door opening
- Holds open from 80° to 180°



Order as 25-H x finish for arm only
Includes: 63-2229 - Main arm and swivel assembly
61-2303 - Foot assembly
63-3481 - Screw pack

F - Fusible Link Hold Open Arm

- Forged Steel Arm 11-1/4" (286mm) long
- Handed same as door
- Friction type holder easily adjustable
- Holds open from 80° to 140°
- 160° F Link Standard
- Specify 125°F Link when required



Order as 25-F x hand x finish for arm only
Includes: 63-2240 - Left hand main arm and link assembly
63-2241 - Right hand main arm and link assembly
63-2468 - Foot assembly
63-3481 - Screw pack

O8 - Mortise Foot Arm

- Forged Steel Arm 11-1/4" (286mm) long
- Non-handed
- Permits 120° door opening
- Commonly used with bull nose frames



Order as 25-O8 x finish for arm only
Includes: 63-2607 - Main arm and link assembly
63-2273 - Foot assembly
63-3481 & 63-2391 - Screw packs

H8 - Mortise Foot Hold Open Arm

- Forged Steel Arm 11-1/4" (286mm) long
- Handed same as door
- Friction type holder easily adjusted by a wrench
- Holds open from 80° to 180°



Order 25 R-H8 for right hand and 25 L-H8 for left hand x finish for arm only
Includes: 63-2229 - Main arm & link assembly
63-2289 - Left hand foot assembly
63-2290 - Right hand foot assembly
63-2290RH - Foot assembly
63-3481 & 63-2391 - Screw packs

F8 - Mortise Foot Fusible Link Hold Open Arm

- Forged Steel Arm 11-1/4" (286mm) long
- Handed same as door
- Friction type holder easily adjusted by a wrench
- Permits 140° door opening
- Holds open from 80° to 140°
- 160° F Link Standard
- Specify 125°F F Link when required

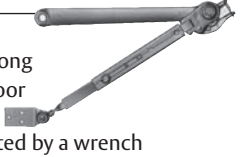

Order as 25-F x hand x finish for arm only
Includes: 63-2240 - Left hand main arm assembly
63-2241 - Right hand main arm assembly
61-2273 - Foot assembly
63-3481 & 63-2391 - Screw packs

OLC - Standard Arm for Low Ceiling

- Forged Steel Arm 11-1/4" (286mm) long
- Non-handed
- Must be used when the distance between the top of door to ceiling is between 1 - 1/4" - 1 - 1/2"
- Permits 120° door opening with standard mounting



Order as 25-OLC x finish for arm only
Includes: 63-2549 - Main arm and link assembly
63-2216 - Foot assembly
63-3481 - Screw pack

UH Package

- Universal hold open arm package provides brackets and arms to install closer in top jamb, standard or parallel applications



Screw packs
63-3481 & 63-2391

125-PH9



UO Package

- Universal arm package provides brackets and arms to install closer in standard top jamb or parallel applications



Screw packs
63-3481 & 63-2391

125-P9



Regular Duty Standard Arms

O10 Heavy Duty Standard Arm

- Forged Steel Arm
- Non-handed
- Permits 110° door opening with standard mounting
- Permits 180° door opening with alternate mounting



Order as 25-O10 x finish for arm only
Includes: 63-0792 - Main arm
63-4309 - Foot assembly
63-3481 - Screw pack

H10 - Hold Open Heavy duty Standard Arm

- Forged Steel Arm
- Non-handed
- Hand is changed by inverting the foot assembly
- Friction type holder easily adjusted by a wrench
- Permits 180° door opening
- Holds open from 80° to 180°



Order as 25-H10 x finish for arm only
Includes: 63-0792 - Main arm
63-4308 - Foot assembly
63-3481 - Screw pack

Top Jamb Applications

281 Series Powerglide®

SARGENT®

ASSA ABLOY

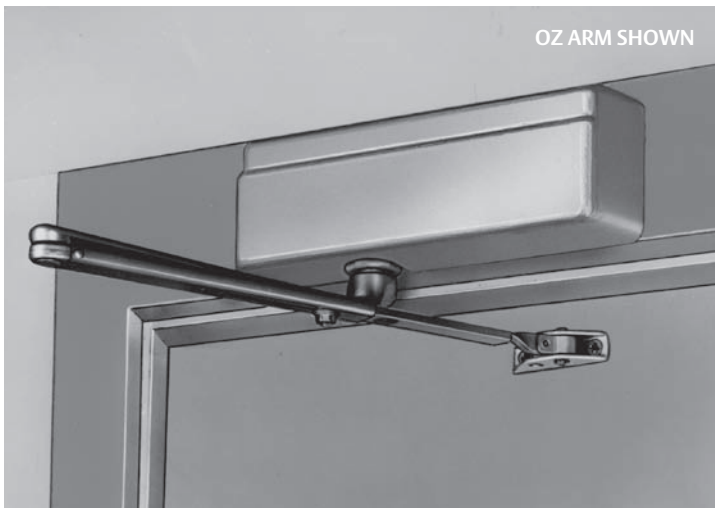

281-O Top Jamb Mounting Position

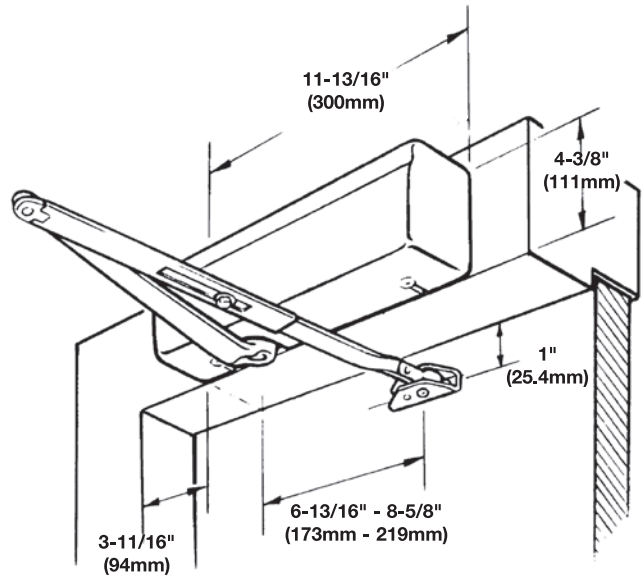

Top Jamb Application - The 281 closer is mounted on the frame face above the door. The foot is mounted on the push side of door. This application is for use on exterior doors opening out to protect the closer from the weather. The Frame Face must be at least 4-3/8". With the 281-B mounting plate, the rail must be at least 1-7/16" min.

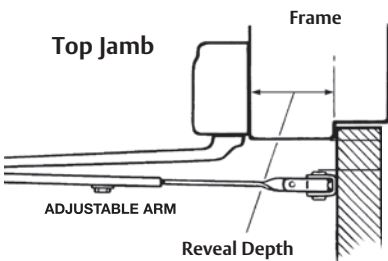

281 Typical Reveal Top Jamb Applications

For reveals up to 2" (51mm) maximum

- O Arm - Max. Door Opening: 180°
- H Arm - Hold Open Range: 80°-180°
- F Arm - Fusible Link Hold Open Arm Hold Open Range: 80°-130°

281 Deep Reveal Top Jamb Applications

For reveals from 2-1/8" (54mm) to 5" (127mm)

- OZ Arm - Max. Door Opening: 140°
- HZ Arm - Hold Open Range: 80°-140°
- FZ Arm - Fusible Link Hold Open Arm Hold Open Range: 80°-130°

281 Extra Deep Reveal Top Jamb Applications

For reveals from 5-1/8" (130mm) to 8" (203mm)

- OZA Arm - Max. Door Opening: 140°
- HZA Arm - Hold Open Range: 80°-130°
- FZA Arm - Fusible Link Hold Open Arm Hold Open Range: 80°-130°

Minimum Frame Face Required

- 4-3/8" minimum frame face for both single and double rabbeted frames
- 1-7/16" minimum frame face with 281-B Mounting Plate

Note: Base on the application & arm; verify door & frame requirements using the appropriate template

Minimum Door Top Rail Required to Mount Closer Foot

- 1-7/8" (48mm) minimum
- Rail height used will vary depending on type and make of auxiliary holder

Note: Base on the application & arm; verify door & frame requirements using the appropriate template

Adjustable Closing Force

- Interior doors to 5'0" wide
- Exterior doors to 4'0" wide
- Shipped factory preset for 3'0" door
- Factory pre-sized upon request

Arm Leverage Adjustment

Closers using "O" or "F" arms have the provision to increase closing power by 15% by adjusting foot pivot

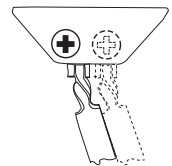

Top Jamb Application for Low Ceilings using 281-B Mounting Plate

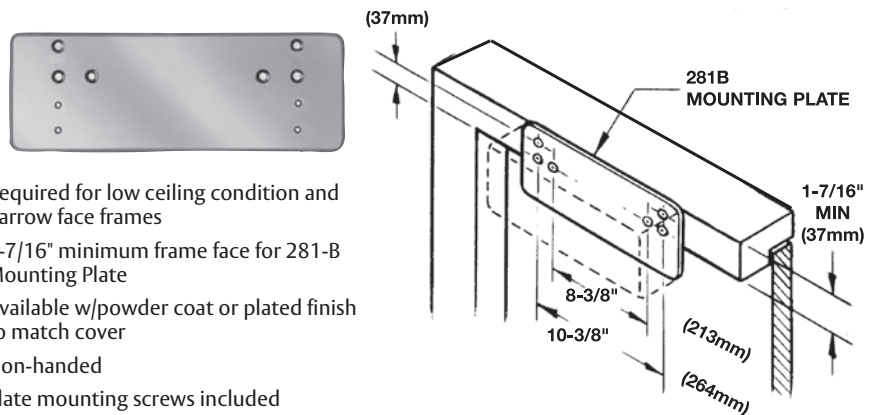

- Required for low ceiling condition and narrow face frames
- 1-7/16" minimum frame face for 281-B Mounting Plate
- Available w/powder coat or plated finish to match cover
- Non-handed
- Plate mounting screws included
- Order as 281-B x finish

Copyright © 2005-2007, 2009-2012, Sargent Manufacturing Company, an ASSA ABLOY Group company. All rights reserved. Reproduction in whole or in part without the express written permission of Sargent Manufacturing Company is prohibited.

901194 11/16/12

Arms for Top Jamb Applications

281 Series Powerglide®

Narrow Reveal Arms

O - Standard Arm

- Forged Steel Arm 11-1/4" (286mm) long
- For reveals up to 2" (51mm)
- Non-handed
- Permits 180° door opening



Order as 25-O x finish for arm only
Includes: 63-2607 - Main arm and link assembly
63-2216 - Foot assembly
63-3481 - Screw pack

H - Hold Open Arm

- Forged Steel Arm 11-1/4" (286mm) long
- For reveals up to 2" (51mm)
- Adjustable friction holder
- Non-handed
- Permits 180° door opening



Order as 25-H x finish for arm only
Includes: 63-2229 - Main arm and link assembly
61-2303 - Foot assembly
63-3481 - Screw pack

F - Fusible Link Hold Open Arm

- Forged Steel Arm 11-1/4" (286mm) long
- For reveals up to 2" (51mm)
- Adjustable friction holder
- Handed same as door
- Permits 140° door opening
- 160° F link standard
- Specify 125° F link when required



Order as 25-F x hand x finish for arm only
Includes: 63-2240 - Left hand main arm and link assembly
63-2241 - Right hand main arm and link assembly
63-2468 - Foot assembly
63-2381 - Screw pack

Deep Reveal Arms

OZ - Standard Arm for Deep Reveals

- Forged Steel Arm 11-1/4" (286mm) long
- For reveals from 2-1/8" (54mm) to 5" (127mm)
- Non-handed
- Permits 140° door opening



Order as 25-OZ x finish for arm only
Includes: 63-2607 - Main arm and link assembly
63-2217 - Foot assembly
63-3481 - Screw pack

HZ - Hold Open Arm for Deep Reveals

- Forged Steel Arm 11-1/4" (286mm) long
- For reveals from 2-1/8" (54mm) to 5" (127mm)
- Adjustable friction holder
- Non-handed
- Permits 140° door opening

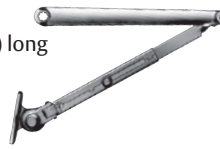

Order as 25-HZ x finish for arm only
Includes: 63-2230 - Main arm and link assembly
61-2303 - Foot assembly
63-3481 - Screw pack

FZ - Fusible Link Hold Open Arm for Deep Reveals

- Forged Steel Arm 11-1/4" (286mm) long
- For reveals 2-1/8" (54mm) to 5" (127mm)
- Adjustable friction holder
- Handed same as door
- Permits 140° door opening
- 160° F link standard
- Specify 125° F link when required



Order as 25-FZ x hand x finish for arm only
Includes: 63-2240 - Left hand main arm and link assembly
63-2241 - Right hand main arm and link assembly
63-2217 - Foot assembly
63-3481 - Screw pack

Extra Deep Reveal Arms

OZA - Standard Arm for Extra Deep Reveal

- Forged Steel Arm 11-1/4" (286mm) long
- For reveals 5-1/8" (130mm) to 8" (203mm)
- Non-handed
- Permits 140° door opening



Order as 25-OZA x finish for arm only
Includes: 63-2607 - Main arm and link assembly
63-2218 - Foot assembly
63-3481 - Screw pack

HZA - Hold Open Arm for Extra Deep Reveal

- Forged Steel Arm 11-1/4" (286mm) long
- For reveals 5-1/8" (130mm) to 8" (203mm)
- Adjustable friction holder
- Non-handed
- Permits 140° door opening



Order as 25-HZA x finish for arm only
Includes: 63-2231 - Main arm and link assembly
61-2303 - Foot assembly
63-3481 - Screw pack

FZA - Fusible Link Hold Open Arm for Extra Deep Reveal

- Forged Steel Arm 11-1/4" (286mm) long
- For reveals 5-1/8" (130mm) to 8" (203mm)
- Adjustable friction holder
- Handed same as the door
- Permits 140° door opening
- 160° F link standard
- Specify 125° F link when required



Order as 25-FZA x hand x finish for arm only
Includes: 63-2240 - Left hand main arm and link assembly
63-2241 - Right hand main arm and link assembly
63-2218 - Foot assembly
63-3481 - Screw pack

Parallel Arm Applications

281 Series Powerglide®

SARGENT®

ASSA ABLOY

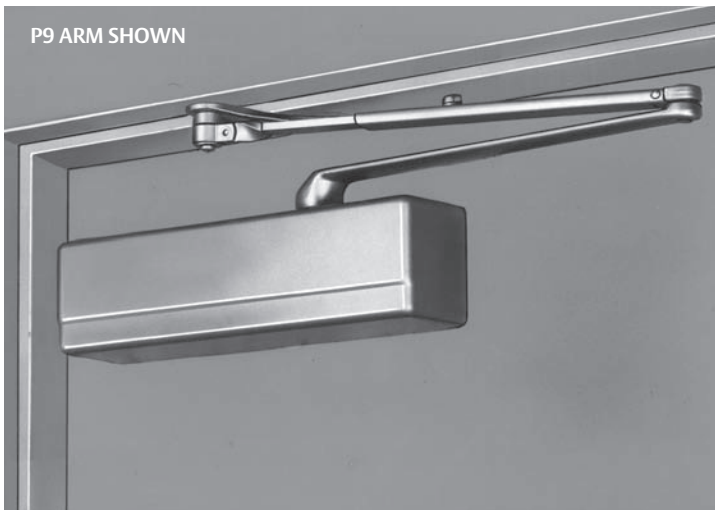

281-P9 Regular Parallel Arm Application

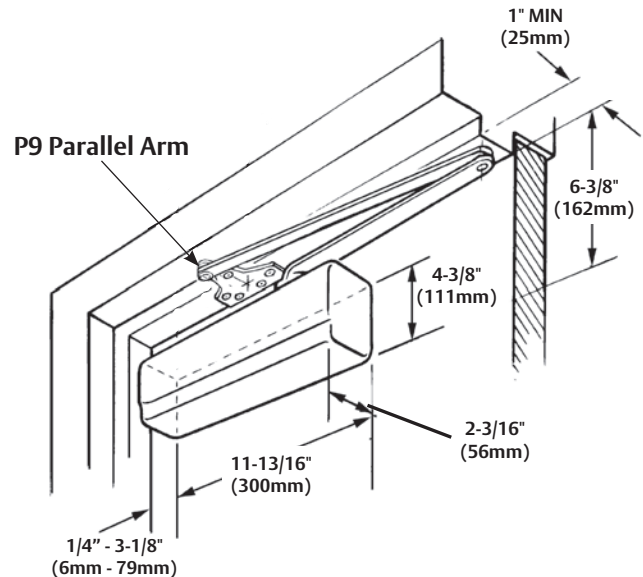

Parallel Arm Application - The 281 closer is mounted on the push side of the door. As the door opens, the closer swings with the door and gives full headroom in the door opening. Other advantages are that the closer arm does not project into the room, the frame can be quite narrow and the door can be swung open much further than in Top Jamb Applications. However, the closing force is not as great.

281-P9 Parallel Application

- 4-3/8" minimum door top rail with a minimum of 6-7/8" unobstructed door top rail

281-P10 Parallel Application

- 5" minimum door top rail with a minimum of 6-3/4" unobstructed door top rail
- 3" minimum soffit, when less than 3" use a 125V bracket

Note: Base on the application & arm; verify door & frame requirements using the appropriate template

Heavy Duty Parallel Arms For use in high traffic and abusive environments

- Forged steel arm and cast iron foot bracket for strength and durability
- Oiled bronze bearings for superior wear resistance
- 2 piece rigid arms for ease of installation
- Friction and positive hold open arms available
- Use friction hold open arms for doors subject to moderate hold open use
- Dead stop and compression stop arms available
- Security non-hold open arms available

Regular Duty Parallel Arms

- For use in moderate duty institutional applications
- Double jointed arm provides flexibility in the vertical mounting position of closer
- Flush frame arms available for use with Auxiliary Holders & Stops
- Flush frame, friction hold open arms available
- Friction and fusible link hold open arms available
- Use friction hold open arms for doors subject to moderate hold open use
- Use offset bracket arms with auxiliary holders and stops

Non hold-open arms

- Two mounting positions for 120° and 180° maximum door openings

Stop & Stop/Hold Open Arms

- 6 mounting positions allow stop from 85° - 110° with PS, PSH, CPS & CPSK arms

Standard Mounting Position

- 120° Maximum door opening
- Holding range of friction and fusible hold open arms: 75° - 110°

Alternate Mounting Position

- Maximum door opening: 180°
- Holding range of friction and fusible hold open arms: 85° - 170°

Heavy Duty Parallel Arms

281 Series Powerglide®

P10 - Heavy Duty Parallel Arm

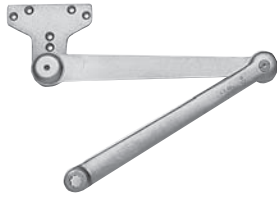

- Forged Steel Arm, 11-1/4" (286mm) long
- Non-handed
- Easily installed
- Permits 120° opening at standard mounting
- Permits 180° opening at alternate mounting

Order as 25-P10 x finish for arm only
Includes: 63-0641 - Main arm
63-3727 - Arm and bracket assembly
63-3481 & 63-2392 - Screw packs

PH10 - Heavy Duty Friction Hold Open Parallel Arm



- Equipped with adjustable friction holder
- Adjustable hold open from 75° to 180°
- Forged steel arm, 11-1/4" (286mm) long
- Handed same as door
- Use friction hold open arms for doors subject to moderate hold open use

Order as 25-PH10 x finish for arm only
Includes: 63-0641 - Main arm
63-3839 - Left hand arm and bracket assembly
63-3840 - Right hand arm and bracket assembly
63-3481 & 63-2392 - Screw packs

PD10 - Heavy Duty Parallel Drop Arm



- Arm to be used with surface overhead applied stops
- Forged Steel Arm, 11-1/4" (286mm) long
- Lowers closer 1-1/4" on door
- Non-handed
- Easily installed
- Permits 120° opening at standard mounting
- Permits 180° opening at alternate mounting

Order as 25-PD10 x finish for arm only
Includes: 63-0641 - Main arm
63-4317 - Arm and bracket assembly
63-3481 & 63-2392 - Screw packs

Heavy Duty Hold Open and Stop Arms

Common features:

- Forged steel arms
- Non-handed
- Easy installed and adjusted

- Use positive stop hold open arms for doors subjected to repetitive hold open

PS - Heavy Duty Parallel Arm with Positive Stop



- Provides built in stop from 85° to 110°

Order as 25-PS x finish for arm only
Includes: 63-0641 - Main arm
63-3837 - Arm and bracket assembly
63-3481 & 63-2392, 63-2396 - Screw packs

CPS - Heavy Duty Parallel Arm with Compression Stop



- Provides built in compression stop from 85° to 105°
- Dead stop within 3°

Order as 25-CPS x finish for arm only
Includes: 63-0641 - Main arm
63-3830 - Arm and bracket assembly
63-0516 - Bumper holder
63-3493 - Bumper
63-3481 & 63-2398 - Screw packs

PSH - Heavy Duty Parallel Hold Open Arm with Positive Stop

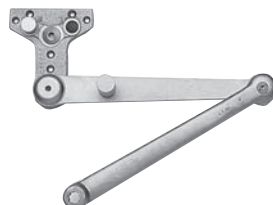

- Adjustable hold open tension
- Hold open function may be disengaged
- Permits 85° to 110° door opening

Order as 25-PSH x finish for arm only
Includes: 63-0641 - Main arm
63-3833 - Arm and bracket assembly
63-3481 & 63-2392, 63-2396 - Screw packs

CPSH - Heavy Duty Hold Open Parallel Arm with Compression Stop



- Adjustable hold open tension
- Hold open function may be disengaged
- Provides built in compression stop and holder mechanism from 85° to 105°
- Dead stop within 3°

Order as 25-CPSH x finish for arm only
Includes: 63-0641 - Main arm
63-3836 - Arm and bracket assembly
63-0516 - Bumper holder
63-3493 - Bumper
63-3481 & 63-3487 - Screw packs

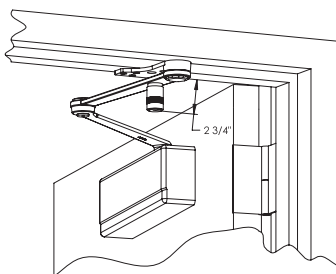

The PSH and CPSH arms project 2-3/4" below the head stop

Regular Duty Parallel Arms

281 Series Powerglide®

Hold Open Arms

P4H - Flush Frame, Friction Hold Open Arm

- Forged Steel Arm 11-1/4" (286mm) long
- Holds open from 75° to 180°
- Easily adjusted by wrench
- Non-handed
- Use on frames where stop or soffit is too narrow to mount the standard hold open foot bracket



Order as 25-P4H x finish for arm only
Includes: 63-2229 - Main arm and link assembly
61-2303 - Foot assembly
64-0050 - Foot bracket
63-3481 & 63-2391 - Screw packs

PH9 - Friction Hold Open Arm

- Forged Steel Arm 11-1/4" (286mm) long
- Holds open from 75° to 180°
- Easily adjusted by wrench
- Non-handed



Order as 25-PH9 x finish for arm only
Includes: 63-2229 - Main arm and link assembly
61-2303 - Foot assembly
64-0039 - Foot bracket (125 PH9)
63-3481 & 63-2391 - Screw packs

PF9 - Fusible Link Hold Open Arm

- Forged Steel Arm 11-1/4" (286mm) long
- Fusible link melts and releases hold mechanism allowing door to close
- 160°F fusible link standard, 125°F link optional
- Equipped with adjustable friction holder
- Holds door open from 75° to 180°
- Easily adjusted by wrench
- Handed same as door

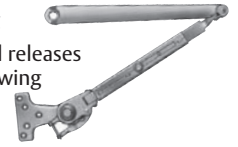

Order as 25-PF9 x hand x fusible link degree x finish for arm only
Includes: 63-2229 - Main arm and link assembly
63-2245 - Left hand foot assembly
63-2246 - Right hand foot assembly
63-3481 & 63-2391 - Screw packs

Offset Bracket Arms

P3 - 1" Offset Bracket for use with Auxiliary Holder/Stop

- Forged Steel Arm 11-1/4" (286mm) long
- For use with auxiliary surface overhead stops and holders
- Foot bracket is offset 1" more than P-9, allowing door closer to be lowered on door face
- Non-handed



Order as 25-P3 x finish for arm only
Includes: 63-2607 - Main arm and link assembly
63-2270 - Foot assembly
63-3481 & 63-2391 - Screw packs

P3A - 1-3/4" Offset Bracket for use with Auxiliary Holder/Stop

- Forged Steel Arm 11-1/4" (286mm) long
- For use with auxiliary surface overhead stops and holders and door coordinators
- Foot bracket lowers door closer an additional 3/4" below P3 bracket
- Non-handed

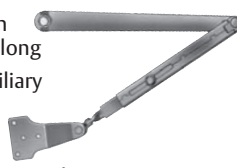

Order as 25-P3A x finish for arm only
Includes: 63-2607 - Main arm and link assembly
63-2274 - Foot assembly
63-3481 & 63-2391 - Screw packs

P4 - 1" Offset Flush Frame Arm for use with Auxiliary Holder/Stop

- Forged Steel Arm 11-1/4" (286mm) long
- Foot bracket is attached to frame or transom face
- Foot bracket is offset 1" more than P9, allowing door closer to be lowered on door face
- For use where stop or soffit is too narrow for the standard P9
- Permits 120° opening with standard mounting
- Permits 180° opening with alternate mounting
- Non-handed

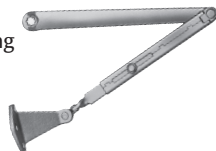

Order as 25-P4 x finish for arm only
Includes: 63-2607 - Main arm and link assembly
63-2295 - Foot assembly
63-3481 & 63-2391 - Screw pack

P4A - 1-3/4" Offset Flush Frame Arm for use with Auxiliary Holder/Stop

- Forged Steel Arm 11-1/4" (286mm) long
- For use with auxiliary surface overhead stops and holders
- Foot bracket is attached to frame or transom face
- Foot bracket lowers door closer an additional 3/4" below P4 bracket
- Non-handed



Order as 25-P4A x finish for arm only
Includes: 63-2607 - Main arm and link assembly
63-2272 - Foot assembly
63-3481 & 63-2391 - Screw packs

P9 - Standard Parallel Arm

- Forged Steel Arm 11-1/4" (286mm) long
- Non-handed

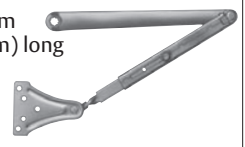

Order as 25-P9 x finish for arm only
Includes: 63-2607 - Main arm and link assembly
63-3405 - Foot assembly
63-3481 & 63-2391 - Screw packs

UO Package

- Universal arm package provides arms and brackets to install closer in standard top jamb or parallel application



Screw packs
63-3481 & 63-2391

125-P9

UH Package

- Universal hold open arm package provides brackets and arms to install closer in top jamb, standard or parallel applications



Screw packs
63-3481 & 63-2391

125-PH9

Accessories For Parallel Applications

281 Series Powerglide®

Heavy Duty Parallel Arm Accessories

581-2 Blade Stop Spacer Kit



- For frames with 1/2" blade stops
 - For use with P10, PH10, PS, PSH, CPS and CPSH arms
 - 125-V bracket included
 - Packed with 1-1/4" long screws
- Use P/N 64-0157 to order blade stop only

125-V/125-VF Brackets



125-V

- For use with all heavy duty parallel arms
- Use 125-V for narrow stop and frame conditions
- Use 125-VF for flush door and frame conditions



125-VF

Spacer 63-0191

- 1/2" x 5/8"
- Included standard with PS, PSH, PH10, P-10 CPS and CPSH arm for use with rabbited frames

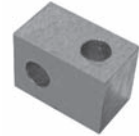

Regular Duty Parallel Accessories

125-P3 Arm Conversion Unit

- Converts O or P9 arm to P3 Parallel Arm



125-P3 Arm Conversion Unit

- Converts O or P9 arm to P3 Parallel Arm



125-P3A Arm Conversion Unit

- Converts O or P9 Arm to P3A Parallel Arm



125-PH9 Parallel Arm Foot

- Converts standard hold open (H) arm to PH9 Parallel Hold Open Arm



125-P4 Conversion Unit

- Converts O or P9 Arm to P4A Arm



125-P4A Arm Conversion Unit

- Converts O or P9 arm to P4A Arm



581-1 Blade Stop Spacer Kit



- For frames with 1/2" blade stops
- For use with P9, PH9 and PF9 arms only
- Packed with 1-1/4" long screws

Miscellaneous Accessories

281 J Cover Plate



- Can be used to improve appearance when narrow door rail permits closer to be viewed through glass panel
- Use 281-J-2 plate when retrofitting 250/251 Series Door Closer

Retrofit Kits #586-1,2,3

The 586 kit allows easy upgrade from existing 250/1250 Series to the 281 Series. Kit includes closer, full cover, fasteners and closer body mounting bracket.

- 586-1 Replaces 250DA and 1250 DA Series
- 586-2 Replaces 250 with advanced backcheck
- 586-3 Replaces 250, 251, 1250 and 1251 Series

281-D Drop Plate



- Required for parallel arm applications when top rails are less than 5 3/4"
- Requires 3" (76mm) minimum top rail
- Available with powder coat or plated finish to match closer
- Non-handed – Plate mounting screws included
- Order as 281-D x finish

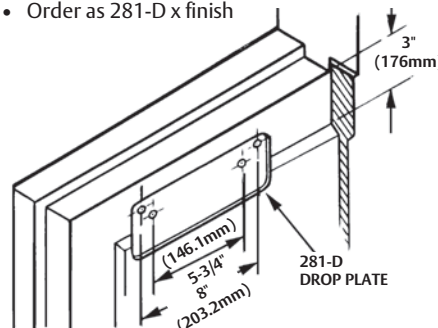

281-W Corner Bracket

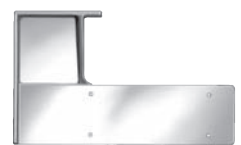

- Fastens securely to both the head and jamb
- Malleable iron, painted to match closer finish
- Non-handed
- Requires 1-1/4" (32mm) minimum wide stop
- Order as 281-W x finish

Covers

- Available in plastic (standard), ABS, Metal, or Lead Lined
- Lead Lined covers are available as a special. Consult factory for pricing.

Track Type Applications

281 Series Powerglide®

SARGENT®

ASSA ABLOY

Pull Side Mounting (Hinge Side)



Push Side Mounting (Stop Side)

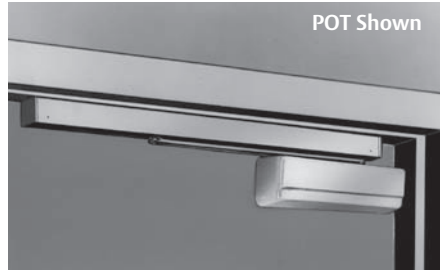

Double Egress Frame Mounting (Stop Side Deep Reveal)

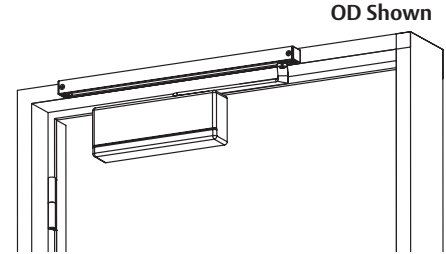

281 Track Type Application offers a number of options such as built in bumpers and holders. Along with its clean appearance, it is a favorite for many interior designers. It has the versatility of being mounted on either side of a door for the clean unobstructed appearance without the cost of concealed closers and tracks.

OT Track Arm

- Track mounts on frame face "OT"
- Minimum top rail required without mounting plate: 2-3/8"

Note: Based on the application; verify door & frame requirements using the appropriate template

Maximum Door Opening

- 160° with standard track
- 120° with optional bumper track
- 180° with ideal conditions for standard track

Hold Open Range

- 85° to 120°

POT Track Arm

- Track mounts on frame stop "POT"
- Minimum top rail required without drop plate: 4-3/4" (121mm)
- With 281D Drop Plate 3" (76mm)

Maximum Door Opening

- 100° with standard track
- 95° with optional bumper track

Hold Open Range

- 85° to 95°

Minimum Soffit Required

- 1-9/16" (40mm) wide

OD Double Egress Track Arm

- Forged steel arm
- Handed
- Special frame profile required
- For use with 3" to 4" reveals
- Non standard frame required

Maximum Door Opening

- 160° with standard track
- 120° with optional bumper track

Hold Open Range

- 85° - 120°

Track

- Extruded aluminum track
- End caps finished to match track

Arm

- Forged steel
- Bearing roller

Bumper (Optional)

- Mounts in track to assist backcheck
- Not designed to be used as a stop
- Auxiliary stop is required
- Available for both regular or hold open tracks

Holder (Optional)

- Mounts within the track
- Adjustable latch tension and position

Finishes

- EAB, EB, ED, EN, EP powder coat on all exposed surfaces

281 OT - Installed in Top Jamb Application. Use template A7975A

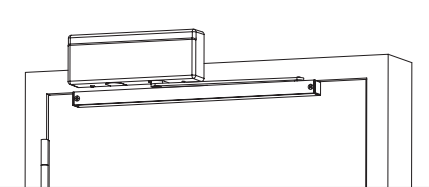

Arm & Track	Description/Options
281—OT	Pull
281—OTB	Pull with Bumper
281—HT	Pull with Holder
281—HTB	Pull with Holder and Bumper
281—OD	Pull Double Egress (Handed) (Non-standard frame required)
281—ODB	Pull Double Egress with Bumper (Handed) (Non-standard frame required)
281—HD	Pull Double Egress with Holder (Handed) (Non-standard frame required)
281—HDB	Pull Double Egress with Holder and Bumper (Handed) (Non-standard frame required)
281—POT	Push
281—POTB	Push with Bumper
281—PHT	Push with Holder
281—PHTB	Push with Holder and Bumper

Note: Two mounting applications are available

Copyright © 2005-2007, 2009-2012, Sargent Manufacturing Company, an ASSA ABLOY Group company. All rights reserved. Reproduction in whole or in part without the express written permission of Sargent Manufacturing Company is prohibited.

901194 11/16/12

Standard & Parallel Arm Security Solutions

281 Series Powerglide®

With its heavy duty cast iron construction, the 281 door closer is an ideal choice when selecting a closer for detention or security applications. While no surface mount door closer is impervious to all situations, the forged steel arms, metal cover and security screws give the 281 line of security closers a high tolerance for extreme abuse.

Standard Heavy Duty Security Applications

When the strongest closing forces are required in rough environments, the SARGENT SSO arm is the best choice.

SSO - Standard heavy duty - pull side

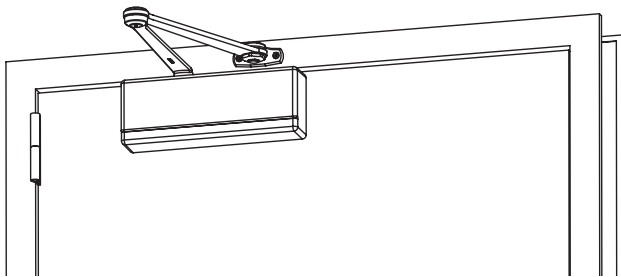

SSO Features:

- Metal cover (handed) with tamper proof security screws
- Factory assembled arm to prevent tampering
- Heavy duty forged steel arms that will endure abuse
- Oil bronze bearings in arms for superior wear resistance
- Non-handed arms and closer - only the cover is handed
- Permits 180° opening with alternate mounting if adjacent frame does not interfere with cover
- All exposed fasteners are Security Torx Machine Screws

Parallel Arm Security Application

The SARGENT parallel application security arm provides increased resistance to abuse with a similar range of closing forces as the SSO.

SSP- Heavy duty - push side

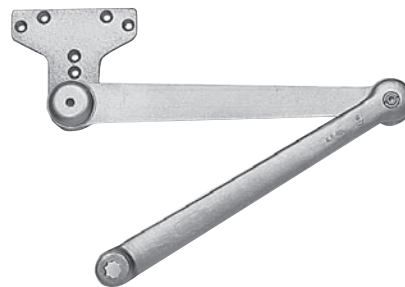
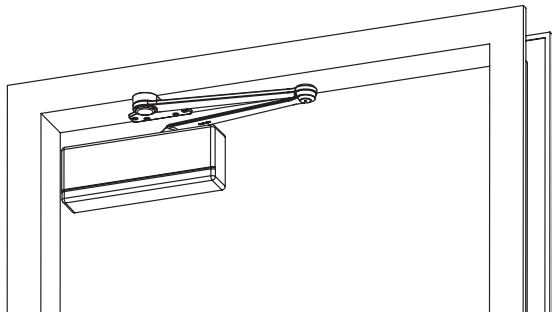

SSP Features:

- Metal cover (handed) with tamper resistant security screws
- Factory assembled arm to prevent tampering
- Heavy duty forged arms that will endure abuse
- Non-handed arm and closer - only the cover is handed
- Oil bronze bearings in arms for superior wear resistance
- Permits 180° opening with alternate mounting if adjacent wall and frame do not interfere with cover
- All exposed fasteners are Security Torx Machine Screws

Track Type Security Solutions

281 Series Powerglide®

SARGENT®

ASSA ABLOY

Security Track Arm Applications

With the arm tucked tightly between the top of the closer and the bottom of the track, SARGENT track type security closers provide the greatest resistance to abuse of any surface mount closer. Push and pull side applications are available.

General Features

- Forged steel arm with integrated roller
- Tamper proof security torx machine screws are provided for all exposed fasteners
- Metal cover (handed)
- Track is mounted to frame with four screws
- Track design ejects foreign objects from within track

SSPT - Pull Side Mounting (Hinge Side)



SSPT Features

- Security track with adapter bar mounted on pull side
- Track mounts to the frame face; minimum width 2-3/8"
- Maximum door opening 160°

Note: Based on the application; verify door & frame requirements using the appropriate template

PSSPT - Push Side Mounting (Stop Side)

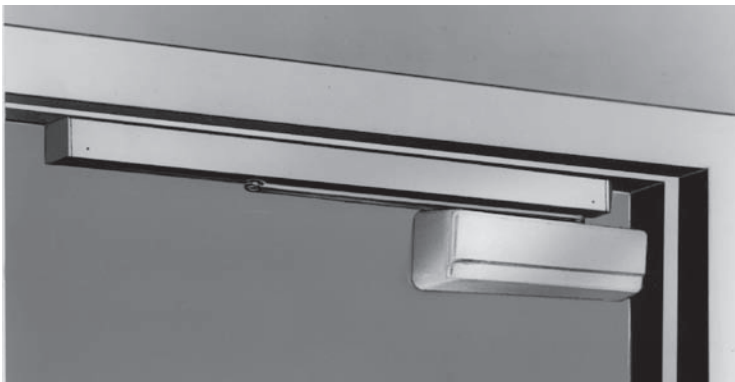

PSSPT Features

- Security track mounts on stop for push side
- Track mounts on frame stop; Minimum stop required 1-11/16"
- Maximum door opening - 100°

Note: Based on the application; verify door & frame requirements using the appropriate template

268 Concealed Security Closers

For the highest degree of security and resistance to abuse, select a SARGENT 268/269 concealed door closer. See our Concealed Door Closer Catalog.

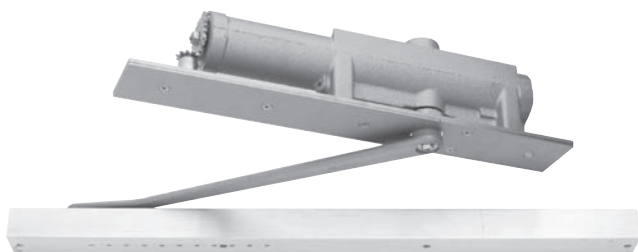

Copyright © 2005-2007, 2009-2012, Sargent Manufacturing Company, an ASSA ABLOY Group company. All rights reserved. Reproduction in whole or in part without the express written permission of Sargent Manufacturing Company is prohibited.

901194 11/16/12

Overhead Stop/Holder Compatibility

281 Series Powerglide®

When a floor or wall stop cannot be used, the highest level of door control is provided through the use of a SARGENT door closer and a SARGENT overhead stop or holder. While door closer arms are available with stop and holder options, they are limited in their ability to withstand extreme abuse. Overhead stops absorb abusive loads using a heavy compression spring that distributes the load to the frame. SARGENT overhead stops and holders are designed for years of abuse and come with a 5 year warranty

Frequently Used Overhead Stops used with the 281 Series

- **Standard Door Closer Applications (PULL SIDE MOUNT) Not Shown**

- 590 Series Holder/Stop with 281-O
- 690 Series Holder/Stop with 281-O
- 1530 Series Holder/Stop with 281-O
- 1540 Series Holder/Stop with 281-O

- **Parallel Arm Door Closer Applications (PUSH SIDE MOUNT)**

- 590 Series Holder/Stop with 281-P3
- 590 Series Holder/Stop with 281-PD10
- 690 Series Holder/Stop with 281-P9
- 690 Series Holder/Stop with 281-P10
- 1530 Series Holder/Stop with 281-P9
- 1530 Series Holder/Stop with 281-P10
- 1540 Series Holder/Stop with 281-P3
- 1540 Series Holder/Stop with 281-PD10

- **Parallel Arm Door Closer Applications Used with a Flush Frame**

- 590 Series Holder/Stop with 281-P4
- 690 Series Holder/Stop with 281-P4
- 1530 Series Holder/Stop with 281-P4
- 1540 Series Holder/Stop with 281-P4

- **Inverted Top Jamb Applications**

- 590, 690, 1530, 1540 Series with either 281, 351, 1430 Series and "O" OZ, OZA Arm

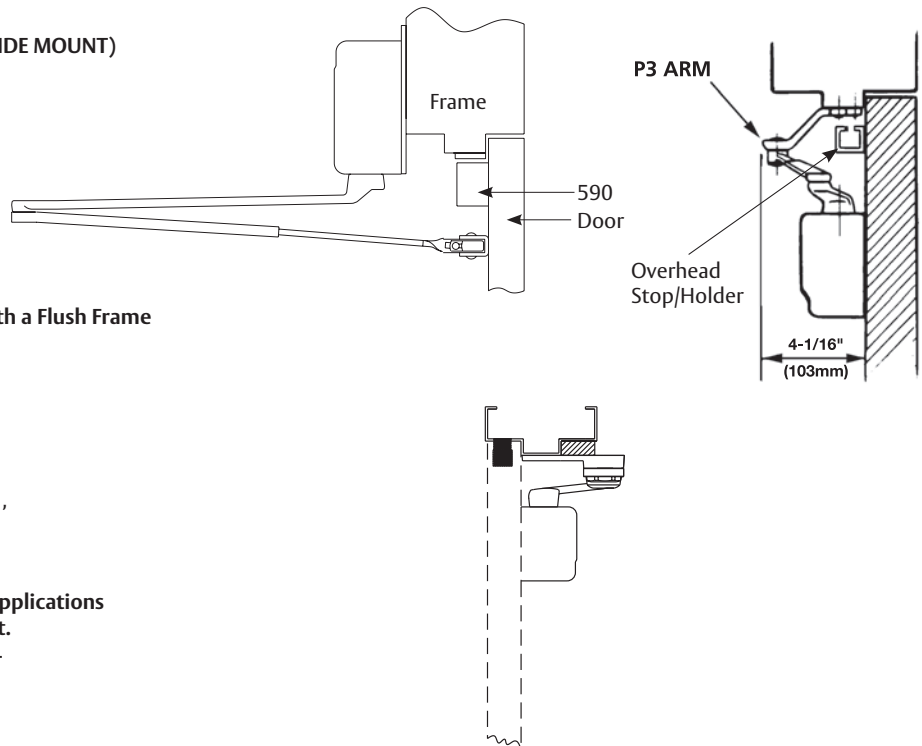

Note: This chart is only a quick reference. Some applications may require the use of a 145 or 195 angle bracket.

For applications not shown, refer to the SARGENT Overhead Holders & Stop catalog.

Special Conditions

The SARGENT Website (www.sargentlock.com) contains templates for all common applications of SARGENT Door Closers with SARGENT overhead door holders. To insure a satisfactory installation for other holders, it is recommended that complete details be submitted as follows:

- Type, size and make of holder
- Holding position (maximum door opening)
- Submit holder template being used
- Closer application being used
- Size and type of hinge

In the case of unusual door, frame and hinge conditions where regular products do not meet requirements, submit drawings and complete details specifying the degree of door openings required, the type and size of hinge and the maximum door opening angle.

Through Bolts and Mortise Nuts

- When through-bolting is ordered, factory will furnish mortise nuts for use with the machine screws furnished with the closer
- Nuts are sized to accommodate 1-3/4" (44mm) standard or 1-3/8" (35mm) thick doors when specified on order
- For 2-1/4" (57mm) thick doors, through-bolts will be furnished with mortise nuts
- A bridge type reinforcement is required to prevent collapse of top rails when through-bolts are tightened (required on hollow metal doors)

How to Order & Options

281 Series Powerglide®

SARGENT®

ASSA ABLOY

Packing

- Closer assemblies are packaged 2 per carton - total weight 20lbs

How to Order

CPC-DA	281-	P4H	26	LH
Options	Series	Closer Arm	Finish	Hand
31- 36- 74- ABC- CPC- DA- MC- SG- SRI- TB- EC-	281	Standard Page 5 Top Jamb Page 7 Parallel Pages 9 & 10 Track Type Page 12	EB ED EN EP EAB 03* 04* 09* 10* 10B* 10BL* 15* 20D* 26* 26D*	LH RH

* These finishes are automatically provided with a metal cover

Options Available

Specify	Detailed Description
31-	For doors 1-7/8" to 2-1/4" thick, specify door thickness, doors over 2-1/4" thick contact factory
36-	Security Torx Screws
74-	Lead lined cover
ABC-	Advanced Back Check
CPC-	Clear Powder Coat (available on 26 & 26D)
DA-	Delayed Action
EC-	ABS Cover
MC	Handed Metal Cover
SG-	MicroShield - an antimicrobial powder coat - supplied standard with metal covers
SRI-	Special Rust Inhibitor finish for powder coated finishes only (arm and body)
TB-	Through Bolt (1-3/4" Std) For others, specify TB- & door thickness

Note:

- The MC- option is also used when a metal cover is desired
- When MC- is added to a plated finish, the MC- option indicates that only the cover is to be plated, the arms will be powder coated to match
- Do not specify the MC- option if both the cover and arms are to be plated

How To Order Accessories

		Example
Arm only	Specify: 25- arm required x finish	25-PSH EN x hand
Closer Body only	Specify: CB-281 (Options DA & ABC available)	CB-281
Arm Conversion Units	Specify: Unit x finish	125-P4 x EB
Cover (Standard plastic)	Specify: 281-C x finish	281-C x EB
Cover (ABS)	Specify: 281-CEC x finish	281-CEC x EP
Accessories	Specify: accessory x finish See applicable catalog section	281-D EB

Note: When complete closer assembly is ordered with an accessory, order accessory as a separate item

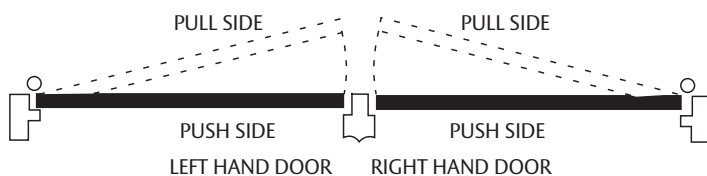

Special Rust Inhibitor Process (SRI)

Additional process available for bracket and arms provides an extra layer of protection for extreme corrosive environments. Available with powder coated finishes only, specify SRI- as an option when ordering.

Finishes

281 Series Powerglide®

SARGENT®

ASSA ABLOY

Finishes

Finishes	ANSI/BHMA	Description
EB	695	Bronze enamel or polyester powder coated to match finish 10B
EN	689	Aluminum enamel or polyester powder coated
ED	693	Black enamel or polyester powder coated to match finish 20D
EAB	696	Brass enamel or polyester powder coated
EP	691	Bronze enamel or polyester powder coated to match finish 10
03	605	Bright brass, clear coated
04	606	Satin brass, clear coated
09	611	Bright bronze, clear coated
10	612	Satin bronze, clear coated
10B	614	Dark oxidized satin bronze, oil rubbed
10BL	614	Oxidized satin, bronze, clear coated
15	619	Satin nickel, clear coated
20D	624	Statuary dark bronze, clear coated
26	625	Bright chromium plated
26D	626	Satin chromium plated

SARGENT Manufacturing Company
100 Sargent Drive, New Haven, CT 06511 USA
800-727-5477 • www.sargentlock.com

Founded in the early 1800s, SARGENT[®] is a market leader in locksets, cylinders, door closers, exit devices, electro-mechanical products and access control systems for new construction, renovation, and replacement applications. The company's customer base includes commercial construction, institutional, and industrial markets.

Copyright © 2005-2007-2009-2012, Sargent Manufacturing Company, an ASSA ABLOY Group company. All rights reserved. Reproduction in whole or in part without the express written permission of Sargent Manufacturing Company is prohibited.

ASSA ABLOY is the global leader in door opening solutions, dedicated to satisfying end-user needs for security, safety and convenience.